

Molded Parts

Meet:Changchun Heat Shrinkable Materials co.,Ltd.
Enterprise Standard

Q/CCRS-37-1999



Authorized on Nov 25,1999; Adopted on Dec 27, 1999
Published by Changchun Heat Shrinkable Materials co.,Ltd.

Molded Parts

1. Scope and Requirements

This standard specified the technical requirement, test method for molded parts and also packing, mark, transportation, storage etc.

This standard is suitable for molded parts whose characteristic constituent are polyethylene.

2. Reference Standard

Where reference is made to other publications, such reference shall be considered to refer to the latest edition and all amendments published

to that edition up to the time when this standard was approved.

| | |
|---------------|--|
| GB1034-1998 | Test methods for water absorption of plastic |
| GB/T1040-1992 | Test methods for tensile properties of plastic |
| GB1408-1989 | Test methods for Dielectric strength of solid electrical insulating materials at Commercial Power Frequencies |
| GB1409-1988 | Test methods for Dielectric constant and loss factor of solid electrical insulating materials at Commercial Power Frequencies, Audio Frequencies and High frequencies. |
| GB1410-1989 | Test methods for Volume Resistivity and surface resistivity of solid electrical insulating materials |
| GB/T1690-1992 | Test methods for effect of liquid of vulcanized rubber |
| GB/T2406-1993 | Test methods for burning behaviour by oxygen index of plastic |
| GB2411-1980 | Test methods for Shore Hardness of plastic |
| GB/T7141-1992 | Plastics-Methods of exposure to thermal air |
| UL224-1992 | Standard for Safety Extruded Insulating Tubing |

3. Type Specification

3.1 Part Numbering System

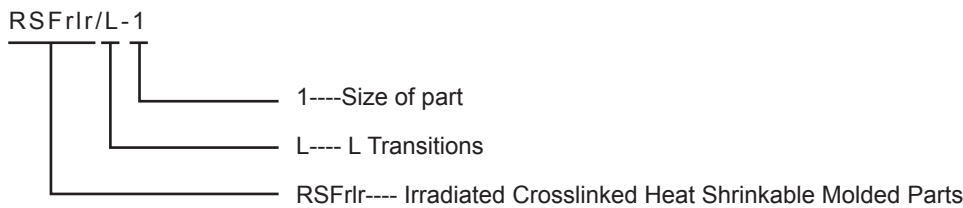

Typical Shapes:

| Application | Typical Shapes | |
|---------------------------|----------------|--|
| I----Straight Transitions | | |
| L---- L Transitions | | |

Molded Parts

Typical Shapes:

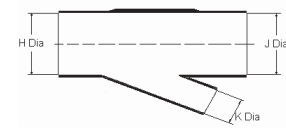
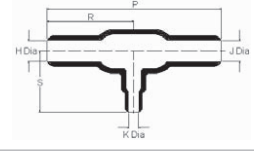
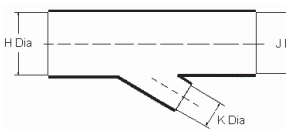
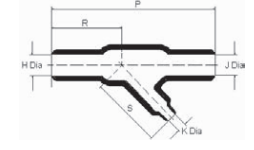
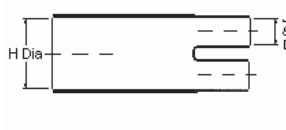
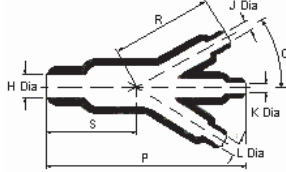
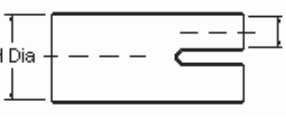
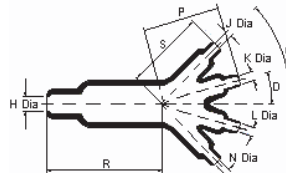
| Application | Typical Shapes | |
|---------------------|---|---|
| T---T Transitions |  |  |
| Y---Y Transitions |  |  |
| S---3:1 Transitions |  |  |
| W---4:1 Transitions |  |  |

4. Description and Dimensions

4.1 RSFrIr/I

Features:

- Heat shrinkable
- Straight Transitions
- Good resistance to heat, fluids
- Continued operating temperature: -55°C~+125°C



Technical Data:

| Property | | Test procedure and condition | Typical Performance | Test Method |
|-------------|------------------------|------------------------------|---------------------|---------------|
| Physical | Water Absorption, % | | ≤0.15 | GB1034-1998 |
| | Radial change, % | 130±2°C/1~3min | ≥50 | |
| | Longitudinal change, % | 130±2°C/1~3min | ≤10 | |
| Mechanical | Shore Hardness,A | | ≤70 | GB2411-1980 |
| | Tensile Strength, MPa | | ≥14.0 | GB/T1040-1992 |
| | Ultimate elongation, % | | ≥500 | GB/T1040-1992 |
| | Cold bend | -10±2°C/1hr | No cracking | UL224-1992 |
| | Heat Shock | 136±1°C/1hr | No cracking | UL224-1992 |
| After aging | Tensile Strength, MPa | 158±1°C/168hr | ≥70% | GB/T7141-1992 |
| | Ultimate elongation, % | 158±1°C/168hr | ≥70% | GB/T1040-1992 |

Molded Parts

Technical Data:

| Property | | Test procedure and condition | Typical Performance | Test Method |
|------------|----------------------------|------------------------------|-----------------------|---------------|
| Electrical | Dielectric Strength, kV/mm | | ≥20 | GB1408-1989 |
| | Volume Resistivity ,Ω.cm | | ≥1.0×10 ¹³ | GB1410-1989 |
| | Dielectric constant | | ≤3.5 | GB1409-1988 |
| Chemical | Shrink temperature, °C | | 120-130 | |
| | flammability, (OI) | | ≥27.0 | GB/T2406-1993 |

Dimensions:

| ORDER REF. NO. | Expanded(mm) | | Recovered(mm) | | | | | |
|----------------|--------------|----|---------------|------|------|---|-----|-----|
| | H | J | H | J | P | S | T | U&V |
| RSFrIr/I-0 | 19 | 19 | 13.8 | 3.9 | 52.5 | 3 | 1 | 12 |
| RSFrIr/I-2 | 24 | 24 | 10.4 | 5.6 | 38 | 3 | 1 | 12 |
| RSFrIr/I-3 | 30 | 30 | 14.2 | 5.9 | 55 | 3 | 1 | 12 |
| RSFrIr/I-4 | 31 | 31 | 18 | 7.1 | 67 | 3 | 1 | 20 |
| RSFrIr/I-5 | 36 | 36 | 22.4 | 8.4 | 80 | 3 | 1 | 20 |
| RSFrIr/I-6 | 43 | 43 | 28.2 | 9.9 | 99 | 3 | 1.7 | 20 |
| RSFrIr/I-7 | 60 | 60 | 35.1 | 15.7 | 130 | 3 | 1.7 | 20 |
| RSFrIr/I-8 | 66 | 66 | 44.5 | 16.8 | 170 | 3 | 2 | 20 |

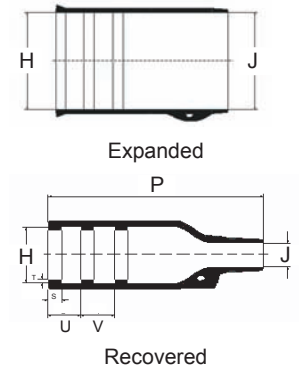

4.2 RSFrIr/L

Features:

- Heat shrinkable
- L Transitions
- Good resistance to heat, fluids
- Continued operating temperature: -55°C~+125°C



Technical Data:

| Property | | Test procedure and condition | Typical Performance | Test Method |
|-------------|----------------------------|------------------------------|-----------------------|---------------|
| Physical | Water Absorption, % | | ≤0.15 | GB1034-1998 |
| | Radial change, % | 130±2°C/1~3min | ≥50 | |
| | Longitudinal change, % | 130±2°C/1~3min | ≤10 | |
| Mechanical | Shore Hardness,A | | ≤70 | GB2411-1980 |
| | Tensile Strength, MPa | | ≥14.0 | GB/T1040-1992 |
| | Ultimate elongation, % | | ≥500 | GB/T1040-1992 |
| | Cold bend | -10±2°C/1hr | No cracking | UL224-1992 |
| | Heat Shock | 136±1°C/1hr | No cracking | UL224-1992 |
| After aging | Tensile Strength, MPa | 158±1°C/168hr | ≥70% | GB/T7141-1992 |
| | Ultimate elongation, % | 158±1°C/168hr | ≥70% | GB/T1040-1992 |
| Electrical | Dielectric Strength, kV/mm | | ≥20 | GB1408-1989 |
| | Volume Resistivity ,Ω.cm | | ≥1.0×10 ¹³ | GB1410-1989 |
| | Dielectric constant | | ≤3.5 | GB1409-1988 |
| Chemical | Shrink temperature, °C | | 120-130 | |
| | flammability, (OI) | | ≥27.0 | GB/T2406-1993 |

Molded Parts

Dimensions:

| ORDER REF. NO. | Expanded(mm) | | Recovered(mm) | | |
|----------------|--------------|----|---------------|------|----|
| | H | J | H | J | P |
| RSFrlr/L-2 | 24 | 24 | 10.2 | 5.3 | 21 |
| RSFrlr/L-3 | 30 | 30 | 14.2 | 6.4 | 27 |
| RSFrlr/L-4 | 32 | 30 | 17.3 | 6.9 | 37 |
| RSFrlr/L-5 | 36 | 36 | 21.8 | 8.4 | 44 |
| RSFrlr/L-6 | 43 | 43 | 27.4 | 9.4 | 54 |
| RSFrlr/L-7 | 53 | 53 | 33.8 | 15 | 76 |
| RSFrlr/L-8 | 67 | 67 | 44.2 | 20.3 | 98 |

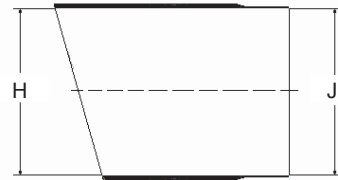

Expanded

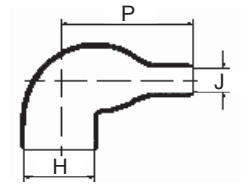

Recovered

4.3 RSFrlr/T

Feathers:

- Heat shrinkable
- T Transitions
- Good resistance to heat, fluids
- Continued operating temperature: -55°C~+125°C

Technical Data:

| Property | | Test procedure and condition | Typical Performance | Test Method |
|-------------|----------------------------|------------------------------|-----------------------|---------------|
| Physical | Water Absorption, % | | ≤0.15 | GB1034-1998 |
| | Radial change, % | 130±2°C/1~3min | ≥50 | |
| | Longitudinal change, % | 130±2°C/1~3min | ≤10 | |
| Mechanical | Shore Hardness,A | | ≤70 | GB2411-1980 |
| | Tensile Strength, MPa | | ≥14.0 | GB/T1040-1992 |
| | Ultimate elongation, % | | ≥500 | GB/T1040-1992 |
| | Cold bend | -10±2°C/1hr | No cracking | UL224-1992 |
| | Heat Shock | 136±1°C/1hr | No cracking | UL224-1992 |
| After aging | Tensile Strength, MPa | 158±1°C/168hr | ≥70% | GB/T7141-1992 |
| | Ultimate elongation, % | 158±1°C/168hr | ≥70% | GB/T1040-1992 |
| Electrical | Dielectric Strength, kV/mm | | ≥20 | GB1408-1989 |
| | Volume Resistivity ,Ω.cm | | ≥1.0×10 ¹³ | GB1410-1989 |
| | Dielectric constant | | ≤3.5 | GB1409-1988 |
| Chemical | Shrink temperature, °C | | 120-130 | |
| | flammability, (OI) | | ≥27.0 | GB/T2406-1993 |

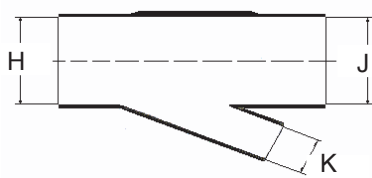

Expanded

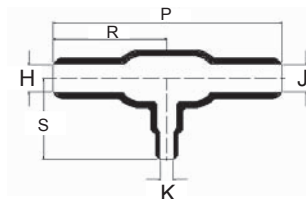

Recovered

| ORDER REF. NO. | Expanded(mm) | | | Recovered(mm) | | | | | |
|----------------|--------------|----|----|---------------|-----|----|-----|----|----|
| | H | J | K | H | J | K | P | R | S |
| RSFrlr/T-A | 13 | 13 | 7 | 5.8 | 5.8 | 3 | 52 | 26 | 19 |
| RSFrlr/T-B | 26 | 13 | 13 | 9 | 9 | 9 | 72 | 36 | 53 |
| RSFrlr/T-C | 54 | 27 | 27 | 13 | 13 | 13 | 120 | 60 | 60 |

Molded Parts

4.4 RSFrIr/Y

Feathers:

- Heat shrinkable
- Y Transitions
- Good resistance to heat, fluids
- Continued operating temperature: -55°C~+125°C



Technical Data:

| Property | | Test procedure and condition | Typical Performance | Test Method |
|-------------|----------------------------|------------------------------|-----------------------|---------------|
| Physical | Water Absorption, % | | ≤0.15 | GB1034-1998 |
| | Radial change, % | 130±2°C/1~3min | ≥50 | |
| | Longitudinal change, % | 130±2°C/1~3min | ≤10 | |
| Mechanical | Shore Hardness,A | | ≤70 | GB2411-1980 |
| | Tensile Strength, MPa | | ≥14.0 | GB/T1040-1992 |
| | Ultimate elongation, % | | ≥500 | GB/T1040-1992 |
| | Cold bend | -10±2°C/1hr | No cracking | UL224-1992 |
| | Heat Shock | 136±1°C/1hr | No cracking | UL224-1992 |
| After aging | Tensile Strength, MPa | 158±1°C/168hr | ≥70% | GB/T7141-1992 |
| | Ultimate elongation, % | 158±1°C/168hr | ≥70% | GB/T1040-1992 |
| Electrical | Dielectric Strength, kV/mm | | ≥20 | GB1408-1989 |
| | Volume Resistivity ,Ω.cm | | ≥1.0×10 ¹³ | GB1410-1989 |
| | Dielectric constant | | ≤3.5 | GB1409-1988 |
| Chemical | Shrink temperature, °C | | 120-130 | |
| | flammability, (OI) | | ≥27.0 | GB/T2406-1993 |

4.4.1 RSFrIr/ Y-A

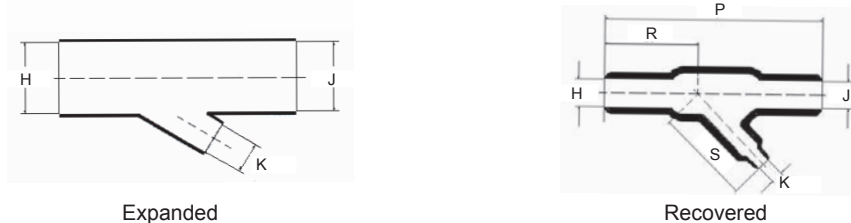

Dimensions:

| ORDER REF. NO. | Expanded(mm) | | | Recovered(mm) | | | | | |
|----------------|--------------|----|----|---------------|------|-----|-----|----|----|
| | H | J | K | H | J | K | P | R | S |
| RSFrIr/Y-A-1 | 13 | 13 | 7 | 6.9 | 6.9 | 3.6 | 49 | 23 | 23 |
| RSFrIr/Y-A-2 | 27 | 27 | 7 | 12.7 | 12.7 | 3.6 | 93 | 41 | 36 |
| RSFrIr/Y-A-3 | 27 | 27 | 13 | 13.7 | 13.7 | 7.4 | 145 | 70 | 54 |

4.4.2 RSFrIr/ Y-B

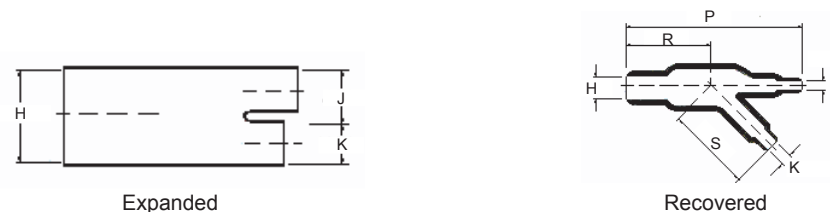

Dimensions:

| ORDER REF. NO. | Expanded(mm) | | | Recovered(mm) | | | | | |
|----------------|--------------|------|------|---------------|-----|-----|----|----|----|
| | H | J | K | H | J | K | P | R | S |
| RSFrIr/Y-B-1 | 26 | 12.4 | 12.4 | 12.4 | 6.1 | 6.1 | 90 | 42 | 43 |

Molded Parts

4.4.3 RSFr/r/ Y-C



Expanded

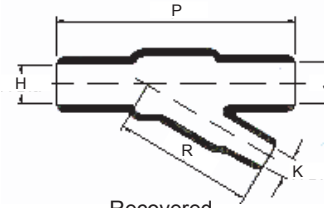

Recovered

Dimensions:

| ORDER REF. NO. | Expanded(mm) | | | Recovered(mm) | | | | |
|----------------|--------------|----|----|---------------|------|------|----|----|
| | H | J | K | H | J | K | P | R |
| RSFr/r/Y-C-1 | 30 | 30 | 20 | 15.7 | 15.7 | 10.7 | 82 | 50 |

4.4.3 RSFr/r/ Y-D

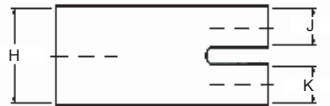

Expanded

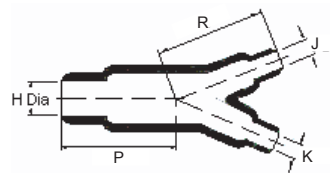

Recovered

Dimensions:

| ORDER REF. NO. | Expanded(mm) | | | Recovered(mm) | | | | |
|----------------|--------------|----|----|---------------|-----|-----|----|----|
| | H | J | K | H | J | K | P | R |
| RSFr/r/Y-D-1 | 13 | 7 | 7 | 6.1 | 3.3 | 3.3 | 22 | 19 |
| RSFr/r/Y-D-2 | 27 | 13 | 13 | 12.4 | 6.1 | 6.1 | 38 | 43 |

4.2 RSFr/r/S

Feathers:

- Heat shrinkable
- 3:1 Transitions
- Good resistance to heat, fluids
- Continued operating temperature: -55°C~+125°C



Technical Data:

| Property | | Test procedure and condition | Typical Performance | Test Method |
|-------------|----------------------------|------------------------------|-----------------------|---------------|
| Physical | Water Absorption, % | | ≤0.15 | GB1034-1998 |
| | Radial change, % | 130±2°C/1~3min | ≥50 | |
| | Longitudinal change, % | 130±2°C/1~3min | ≤10 | |
| Mechanical | Shore Hardness,A | | ≤70 | GB2411-1980 |
| | Tensile Strength, MPa | | ≥14.0 | GB/T1040-1992 |
| | Ultimate elongation, % | | ≥500 | GB/T1040-1992 |
| | Cold bend | -10±2°C/1hr | No cracking | UL224-1992 |
| | Heat Shock | 136±1°C/1hr | No cracking | UL224-1992 |
| After aging | Tensile Strength, MPa | 158±1°C/168hr | ≥70% | GB/T7141-1992 |
| | Ultimate elongation, % | 158±1°C/168hr | ≥70% | GB/T1040-1992 |
| Electrical | Dielectric Strength, kV/mm | | ≥20 | GB1408-1989 |
| | Volume Resistivity ,Ω.cm | | ≥1.0×10 ¹³ | GB1410-1989 |
| | Dielectric constant | | ≤3.5 | GB1409-1988 |
| Chemical | Shrink temperature, °C | | 120-130 | |
| | flammability, (OI) | | ≥27.0 | GB/T2406-1993 |

Molded Parts

Dimensions:

| ORDER REF. NO. | Expanded(mm) | | Recovered(mm) | | | | | |
|----------------|--------------|-------|---------------|-------|-----|----|----|-----|
| | H | J,K&L | H | J,K&L | P | R | S | C |
| RSFrIr/S-1 | 13 | 7 | 6.6 | 3.6 | 46 | 25 | 21 | 300 |
| RSFrIr/S-2 | 27 | 13 | 13.2 | 6.9 | 93 | 50 | 43 | 300 |
| RSFrIr/S-3 | 39 | 19 | 18.8 | 9.7 | 135 | 74 | 62 | 300 |

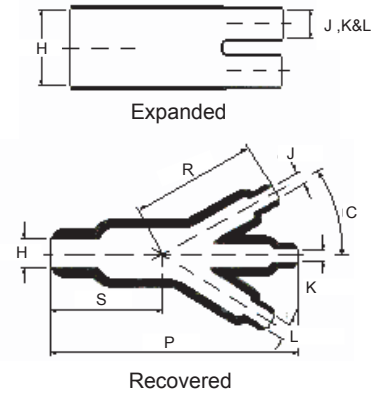

4.2 RSFrIr/w

Features:

- Heat shrinkable
- 4:1 Transitions
- Good resistance to heat, fluids
- Continued operating temperature: -55°C~+125°C



Technical Data:

| Property | | Test procedure and condition | Typical Performance | Test Method |
|-------------|----------------------------|------------------------------|-----------------------|---------------|
| Physical | Water Absorption, % | | ≤0.15 | GB1034-1998 |
| | Radial change, % | 130±2°C/1~3min | ≥50 | |
| | Longitudinal change, % | 130±2°C/1~3min | ≤10 | |
| Mechanical | Shore Hardness,A | | ≤70 | GB2411-1980 |
| | Tensile Strength, MPa | | ≥14.0 | GB/T1040-1992 |
| | Ultimate elongation, % | | ≥500 | GB/T1040-1992 |
| | Cold bend | -10±2°C/1hr | No cracking | UL224-1992 |
| | Heat Shock | 136±1°C/1hr | No cracking | UL224-1992 |
| After aging | Tensile Strength, MPa | 158±1°C/168hr | ≥70% | GB/T7141-1992 |
| | Ultimate elongation, % | 158±1°C/168hr | ≥70% | GB/T1040-1992 |
| Electrical | Dielectric Strength, kV/mm | | ≥20 | GB1408-1989 |
| | Volume Resistivity ,Ω.cm | | ≥1.0×10 ¹³ | GB1410-1989 |
| | Dielectric constant | | ≤3.5 | GB1409-1988 |
| Chemical | Shrink temperature, °C | | 120-130 | |
| | flammability, (OI) | | ≥27.0 | GB/T2406-1993 |

Dimensions:

| ORDER REF. NO. | Expanded(mm) | | Recovered(mm) | | | | | |
|----------------|--------------|---------|---------------|---------|-----|-----|----|-----|
| | H | J,K,L&N | H | J,K,L&N | P | R | S | C |
| RSFrIr/W-1 | 13 | 7 | 6.9 | 3.6 | 24 | 38 | 24 | 450 |
| RSFrIr/W-2 | 19 | 9 | 9.7 | 5.3 | 36 | 36 | 32 | 450 |
| RSFrIr/W-3 | 19 | 13 | 9.7 | 6.9 | 49 | 36 | 45 | 450 |
| RSFrIr/W-4 | 27 | 13 | 13 | 6.9 | 49 | 52 | 45 | 450 |
| RSFrIr/W-5 | 39 | 19 | 18.5 | 9.7 | 72 | 75 | 65 | 450 |
| RSFrIr/W-6 | 56 | 27 | 26.7 | 13 | 102 | 109 | 93 | 450 |

